



AIRLEVATOR<sup>®</sup>



# Benefits

- No pit excavation, hoist-way, or machine room required.
- Clean, quick and easy installation.
- Two, three and four stops (10.5m total rise)
- Ideal for new and existing homes due to the minimal footprint required to accommodate the structure.
- Self-supporting structure.
- “Green elevator”: minimal energy consumption.
- Elegant design. Panoramic 360 °.
- Minimal maintenance.
- Absolute safety: in the event of a power failure, the elevator cab automatically descends to the lowest level and the electromechanical door opens to allow passengers to exit.
- Long life.



# Components

Parts of the elevator

## Exterior Cylinder

Made up of an aluminum frame and polycarbonate panels.

## Elevator Car

Made of steel, which houses the brake and safety mechanisms along with the proprietary seal located on top of the car.

## Suction Assembly

Two formats:  
- Head unit  
- Split unit

# Technical Specifications

## Head Unit

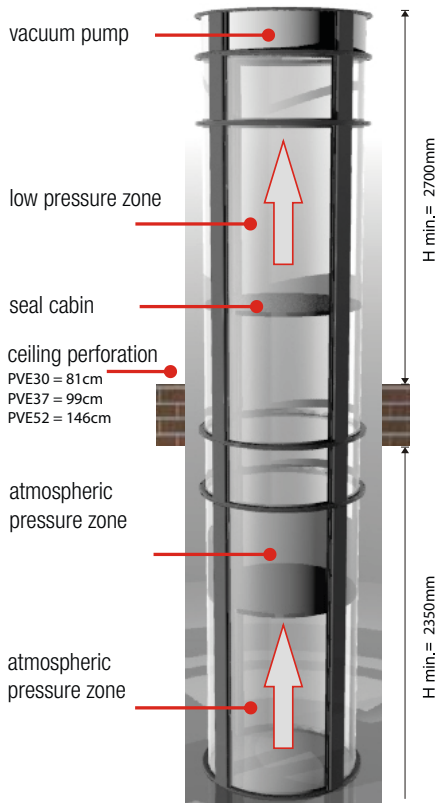

## Split Unit

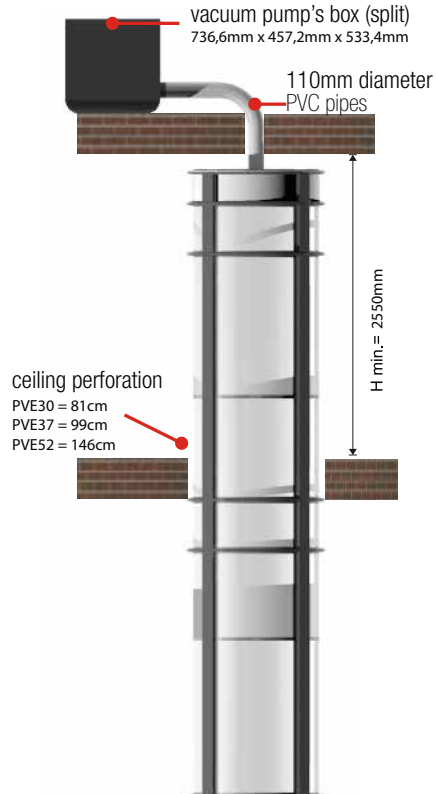

# Options & Upgrades

## Standard Colors

- White
- Bluish Gray

## Special Colors

- Taupe
- Light Gray
- Black

## Accessories

- Foldable Car Seat (PVE37 Only)
- Cabin Key Lock

# Models

## Mini

- **Power supply** 220 VAC - 60/50 Hz
- **Electronic circuit** Command and control 24 V
- **Motor power** 3 kW
- **Speed** 9 m/min or 15 cm/sec
- **Dimensions** External cylinder diameter 750 mm  
Internal cabin diameter 630 mm  
Internal cabin height 2007 mm
- **Total weight** 250 kg (up to 3 m of travel)
- **Maximum load** 159 kg (1 passenger)
- **Equipment** Automatic lighting and fan, phone
- **Warranty:** Two years from installation
- Machinery Directive 2006/42/EC
- CE marking

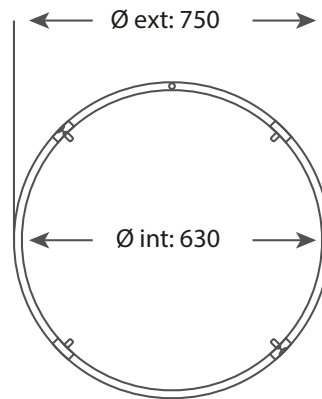

## Midi

- **Power supply** 220 VAC - 60/50 Hz
- **Electronic circuit** Command and control 24 V
- **Motor power** 5 kW
- **Speed** 9 m/min or 15 cm/sec
- **Dimensions** External cylinder diameter 933 mm  
Internal cabin diameter 828 mm  
Internal cabin height 2007 mm
- **Total weight** 350 kg (upt to 3 m of travel)
- **Maximum load** 205 kg (2 passengers)
- **Equipment** Automatic lighting and fan, phone
- **Warranty:** Two years from installation
- Machinery Directive 2006/42/EC
- CE marking

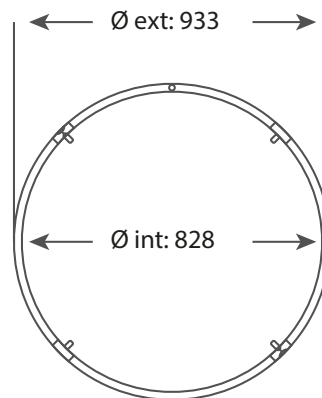

## Maximus

- **Power supply** 220 VAC - 60/50 Hz
- **Electronic circuit** Command and control 24 V
- **Motor power** 6 kW
- **Speed** 9 m/min or 15 cm/sec
- **Dimensions** External cylinder diameter 1316 mm  
Internal cabin diameter 1220 mm  
Internal cabin height 2007 mm
- **Total weight** 530 kg (up to 3 m of travel)
- **Maximum load** 238 kg (3 passengers)
- **Equipment** Automatic lighting and fan, phone
- **Warranty:** Two years from installation
- Machinery Directive 2006/42/EC
- CE marking

